

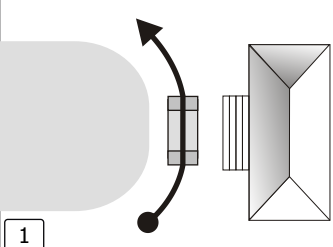

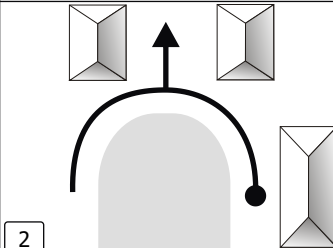

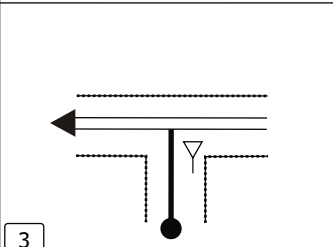





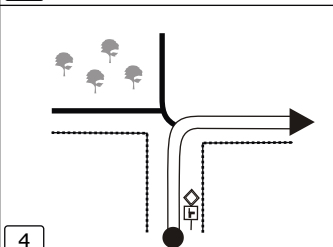

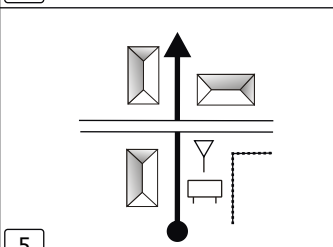
TC - HQ (Biuro Rajdu)		DISTANCE:	DAY:	
TC - Scrutineering (BK-1)		2,37 km	SECTION:	
SPECIAL STAGE		AVERAGE:	TIME ALLOWED:	
DISTANCE		DIRECTION	INFORMATION	DISTANCE REGRESS.
TOTAL	PARTIAL			
0,00	0,00	 1	BIURO RAJDU N- 51° 35' 15.82" E- 21° 33' 16.72"	2,37
0,08	0,08	 2		2,29
0,21	0,13	 3		2,16
0,28	0,07	 4		2,09
0,52	0,24	 5	 	1,85

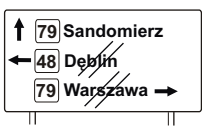
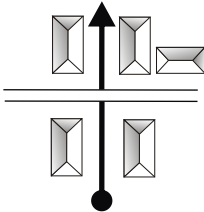
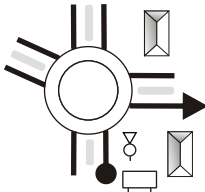
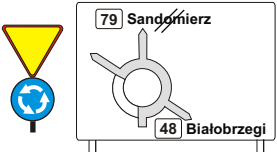
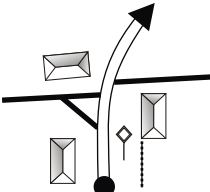
TC - HQ (Biuro Rajdu)		DISTANCE:	DAY:	
TC - Scrutineering (BK-1)		2,37 km	SECTION:	
SPECIAL STAGE		AVERAGE:	TIME ALLOWED:	
DISTANCE		DIRECTION	INFORMATION	DISTANCE REGRESS.
TOTAL	PARTIAL			
0,73	0,21	 6		1,64
0,90	0,17	 7		1,47
1,08	0,18	 8		1,29
1,48	0,40	 9		0,89
1,75	0,27	 10	① PARKING ALTERNATYWNY DLA LAWET	0,62

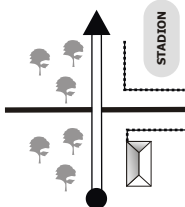
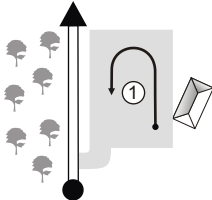
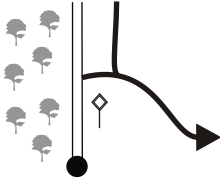
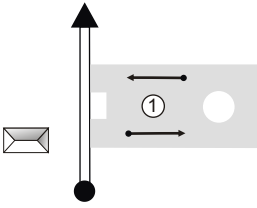
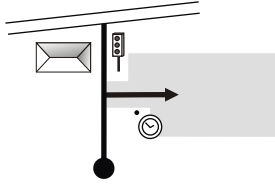
TC - HQ (Biuro Rajdu)		DISTANCE:	DAY:	
TC - Scrutineering (BK-1)		2,37 km	SECTION:	
SPECIAL STAGE		AVERAGE:	TIME ALLOWED:	
DISTANCE		DIRECTION	INFORMATION	DISTANCE REGRESS.
TOTAL	PARTIAL			
1,95	0,20	 <input type="checkbox"/> 11		0,42
2,08	0,13	 <input type="checkbox"/> 12	① PARKING ALTERNATYWNY DLA LAWET	0,29
2,37	0,29	 <input type="checkbox"/> 13	 BK N- 51° 35' 26. 27" E- 21° 32' 31. 49"	0,00
		<input type="checkbox"/>		
		<input type="checkbox"/>		